

MultiLoad II SMP Specification



MultiLoad II SMP (Single Meter Preset) is a microprocessor based electronic preset designed for batch delivery of liquids. This economical package performs single-arm, straight product loading. Capable of injecting up to two additives, MultiLoad II SMP is offered in three different enclosure options: small Division 1 enclosure, larger Division 1 enclosure, or Division 2 enclosure. MultiLoad II SMP can operate with an automation system or offer powerful features when operating in a stand-alone mode.

Features:

- Full Color LCD Display
- Division 1 and Division 2 Enclosures
- Alphanumeric Keypad*
- Integrated Card Reader Option*
- Metered Additive Injection, Supporting Two Injectors
- Automatic Temperature and Pressure Correction
- Event Log and Metrological Audit Trail
- Four-point Linearization
- Automated Proving
- Multi-lingual Support
 - » Mandarin, English, French, Portuguese & Spanish
- 10/100 Mb Ethernet Port
- Serial Communication Ports (3)
- Up to 300 Driver IDs/PINs in Stand-alone Mode
- Stores 10,000 Transactions in Stand-alone Mode
- Automated Proving
- Custom Logic
- User Configurable Operating Parameters

*Excludes Small Division 1 Enclosure

Applications:

The SMP is ideally suited for batch loading of liquids, where legally relevant metrology is required. It is used at terminals, bulk plants, ethanol processing facilities, aviation loading and chemical plants. MultiLoad II SMP supports loading of gasoline, alcohol, LPG, LNG, fuel oil, chemicals and more.

Additive Injection:

Metered additive injectors and Piston injectors are supported, offering the advantage of direct injector control by MultiLoad II SMP. Indirect control of additive injection via Smart Injectors is also supported. Two injectors can be operated simultaneously and the types of injectors can be different.

The Metered Injector method assumes that a liquid flow measurement device is metering additive as it enters the product stream, providing pulses representative of flow. Additive delivery is via a solenoid operated valve. MultiLoad II SMP opens and closes the valve as needed to maintain the proper additive-to-product ratio.

Piston style injectors provide a fixed volume per injection, which is programmed into MultiLoad II SMP. A provision is made to receive a confirmation signal from the piston injector, indicating that the piston has completed an injection cycle. The additive's totalizer is incremented upon confirmation.

Using the Smart Injector method, discrete signals are used to either signal injections or arm the injector for use. Using discrete signals, MultiLoad II SMP monitors the status of the external, microprocessor based device. The Smart Injector will police itself during delivery, reporting alarm conditions to MultiLoad II SMP via discrete output. The extensive additive control features of MultiLoad II SMP are thus relegated to the Smart Injector.

MultiLoad II SMP provides a host of additive control features to support a terminal's unique requirements. Additive flushing, alarming, front-loading of dye, automated calibration and external hardware operation are some of the many additive control features offered for injectors that allow direct control.



MultiLoad II SMP Specification

Temperature Correction

Volume can be corrected to a reference temperature using one of the many temperature correction tables of ASTM-D-1250. The following tables are available. 6A, 6B, 6C, 6D, 24A, 24B, 24E, 53B, 54, 54A, 54B, 54C, 54D, TEC, TEC-ETH. Additional tables can be added upon request.

Pressure Correction

Pressure correction is available for use with compressible products, such as LPG. API tables 11.2.2 and 11.2.2M are provided and require that pressure be measured by MultiLoad II SMP, using a 4-20 mA transducer.

Automated Proving

This mode is entered when the Weights and Measures switch is activated. Prior to the proving run, the operator can select a flow rate to prove. Following the proving run, the operator enters the observed volume and temperature. New meter factors are automatically calculated and can be entered by a button press when approved by the operator. Alternatively, the operator can skip the calculation process and enter independently calculated meter factors through the operator screen, avoiding the need to enter program mode for data entry.

Protocols Supported

In addition to supporting Toptech's own open communication protocol, the MultiLoad II SMP may utilize the Modbus-RTU protocol to communicate with a host computer or directly with a Krohne OPTIMASS series mass meter. Toptech's native protocol is openly published and available to any vendor that wishes to write a communication interface with MultiLoad products.

- MultiLoad Native Open Protocol
- Modbus-RTU Protocol

Pulse Security

Provision is made for dual meter pulse train for the product flow meter, in order to continuously monitor meter pulser integrity. Level B monitoring and indication is provided per API Petroleum Measurement Standard Chapter 5.5.

Valve Control

The MultiLoad II SMP is capable of controlling most common block or digital control valves via one or more AC Outputs. In addition, the SMP is capable of providing analog valve control by utilizing the 4-20mA output provided on the I/O board.

MultiLoad II SMP Specification

Specifications

Operating Temperature:

-25°C to 60°C (-40°C with Optional Heater)

Electromagnetic Compatibility:

Complies with Electromagnetic Compatibility Requirements:
IEC 61000-6-2, IEC 61000-6-4

Instrument Power:

- AC: 85-250 VAC, 47-63 Hz, 300-150 mA
- DC: 18-36 Vdc, 600 mA

Digital Inputs and Outputs:

Digital I/O Count (13)

- A/C Output (5) +85-250 Vrms, 0.5A
- DC Input (5) +5-30 Vdc
 - Dual Channel Flow Meter Input (0-5000 Hz)
 - Single Channel Flow Meter Input (0-10 KHz)
 - Three Inputs for Miscellaneous Signals
- DC Output (3) +0-30 Vdc, 0.6A
 - +12 Vdc Supply for pre-amps/pulsers, 2W, Isolated

Analog Inputs and Outputs:

RTD Input (1)

- 100 Ohm Platinum, 4-wire
- Coefficient 0.00385 $\Omega/\Omega/^\circ\text{C}$
- Accuracy: +/-0.05°C
- 24 Bit ADC

Analog Input (1)

- 4-20mA, +/-0.25%
- 24 Bit ADC

Analog Outputs (1)

- 4-20mA, +/-0.25%
- 16 Bit DAC

Communications Ports:

- Serial Ports (3)
 - RS-232 (1)
 - RS-485 (1)
 - Selectable RS232/485 (1)
- 10/100 Mb Ethernet (1)

SMP Enclosure Options



Small SMP Enclosure (Division 1)



EXL Enclosure (Division 1)



Division 2 Enclosure

Features

- Numeric Keypad
- 4" (Diagonal) Color Display

Dimensions

- 8.5" x 8.5" x 5.5"
- 219mm x 219mm x 139mm

Compliance Information

- Class I, Division 1, Groups C & D
- Inmetro Certified
- ATEX Group IIB, Category 2G

Features

- Cell Phone Style Alphanumeric Keypad
- 5.7" (Diagonal) Color Display
- Integrated Card Reader Option

Dimensions

- 11.5" x 11.5" x 6"
- 289mm x 289mm x 151mm

Compliance Information

- Class I, Division 1, Groups C & D
- Inmetro Certified
- ATEX Group IIB, Category 2G
- IECEx Group IIB, Category 2G

Features

- Full Alphanumeric Keypad
- 8.4" (Diagonal) Color Display
- Integrated Card Reader Option

Dimensions

- 18" x 12.25" x 5"
- 459mm x 311mm x 125mm

Compliance Information

- Class I, Division 2, Groups C & D
- CE Marked
- ATEX Group IIB, Category 3G

MultiLoad II SMP Specification

Typical Installation

The MultiLoad II SMP (Single Meter Preset) is equipped with an internal I/O board capable of handling single product delivery with up to two additives. The MultiLoad II SMP is designed to be highly flexible. The diagram below is meant to illustrate a typical installation of the product.

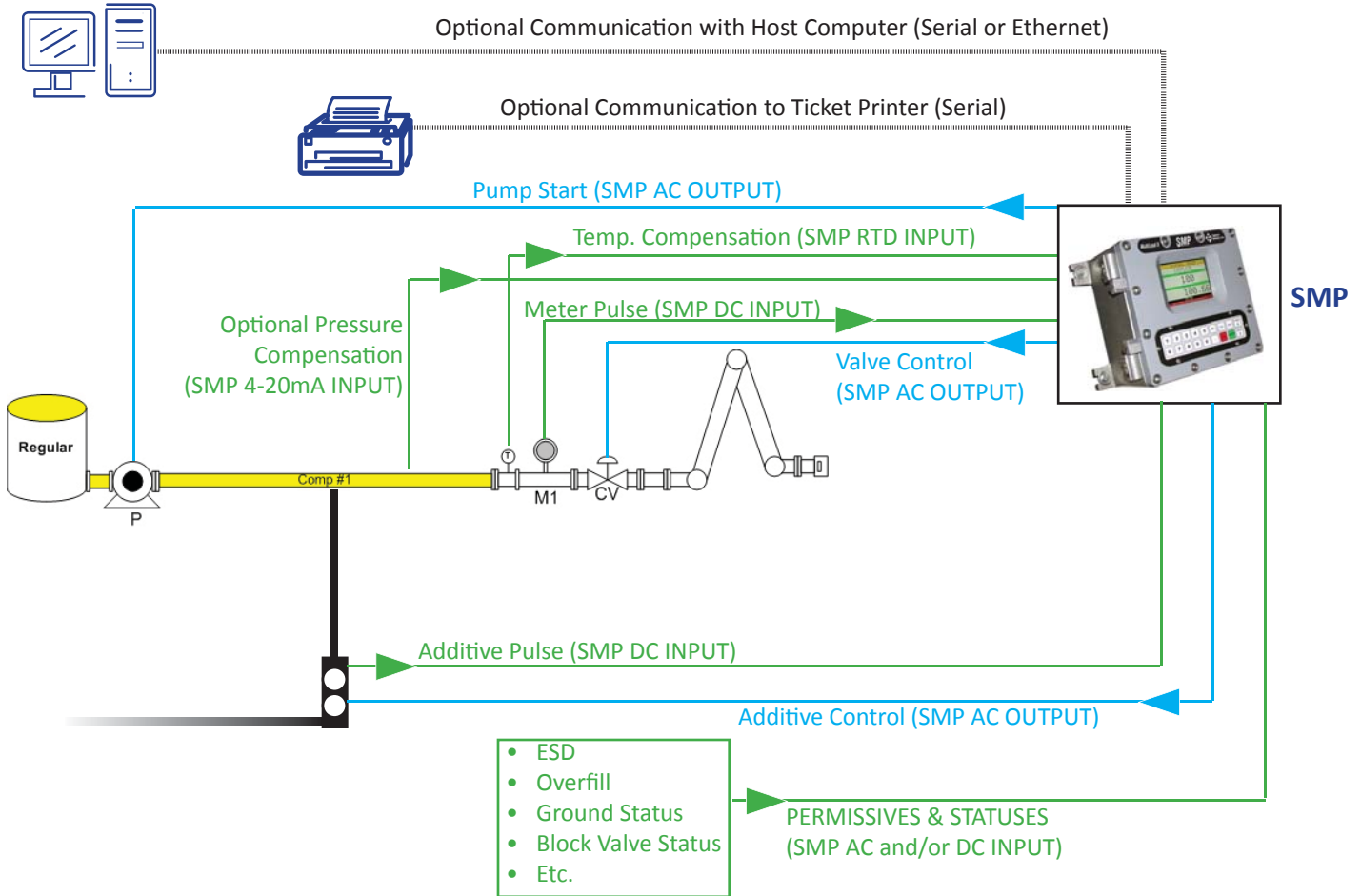

SMP Matrix

Product	Part Number	Enclosure			Firmware		Card Reader		I/O Board		Power	
		1	2	3	1	2	1	2	1	2	1	2
		Division 2	EXL (Large Division 1)	SMP (Small Division 1)	MultiLoad II Package	SMP	No Card Reader	Captive Proximity Reader	SMP Digital & Analog In/Out	2-meter Digital & Analog In	AC (100-260 VAC)	DC (18-36 VDC)
SMP	2313	S	X	X	U	S	S	O	S	U	O	O
SMP	4804	X	S	X	U	S	S	O	S	U	O	O
SMP	4809	X	X	S	X	S	S	X	S	U	O	O
Notes		Enclosure selection dictates part number			MultiLoad Package Firmware requires product upgrade		Option for EXL and Division 2 enclosures		2-meter internal I/O board is available in Div 2 and EXL Enclosures. Requires upgrade to MultiLoad II Package Firmware		Requires selection of either AC or DC	

S = Standard

O = Option

X = Not Available

U = Requires Upgrade